



**Jeppesen PRIMAR ECDIS Service  
Innovations in ENC Distribution**

Eric James  
Sales Manager - N. America



## C-MAP Professional+

- Global Vector Database
  - Approx. 18,000 chart files
- CM-93/3 Data Format (SENC)
- Privately produced electronic charts
- Not authorized to meet chart carriage requirements

## PRIMAR ENC Service

- Global ENC Database
  - Approx. 8,500 chart files
- S-57 Data Format
- Official ENC coverage.
- Authorized to meet ECDIS chart carriage regulations

# Jeppesen PRIMAR ECDIS Service

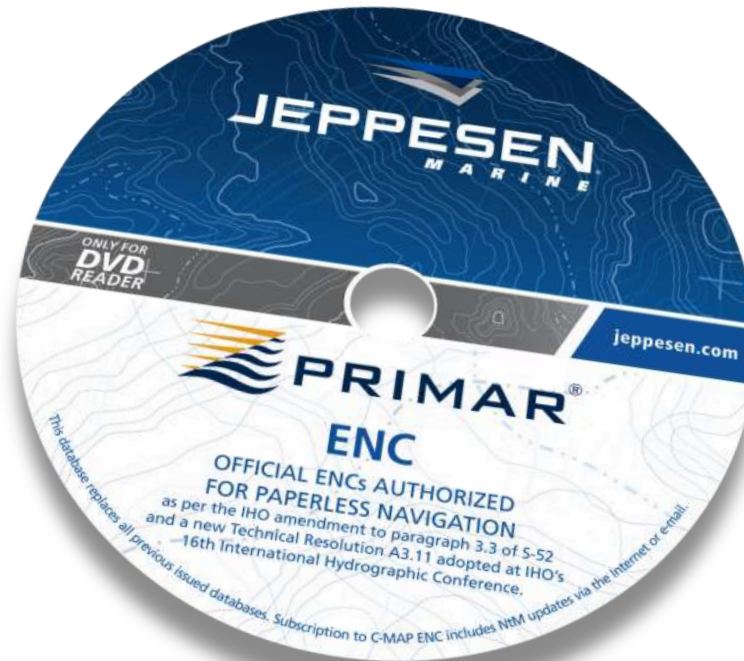

# Jeppesen PRIMAR ENC Service

Combining the best of both worlds...



- Official PRIMAR ENC where available, C-MAP Professional+ to fill the gaps in ENC coverage.
- As new ENC's are added they replace the unofficial chart. Eventually a pure ENC distribution service.
- Distributed in the CM-93 SENC format



# ENC distribution from Jeppesen



ENC distribution in SENC format

1. One DVD replaces multiple base and update CDs sent to vessel
2. All ENC's loaded and ready to license
3. No decryption onboard
4. No verification onboard
5. No Compilation onboard from S-57 to SENC
6. Simplified licensing

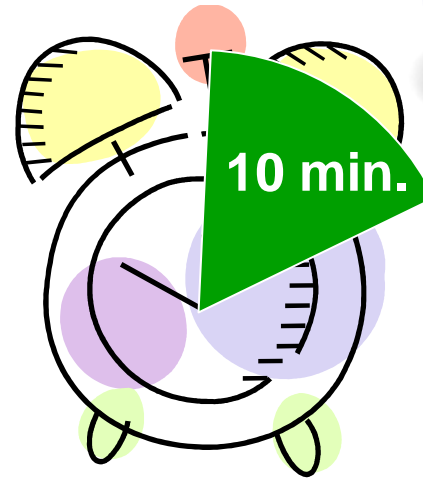

# C-MAP Online

- **Downloads Notices to Mariners Only**
- **Can use direct Internet connection or email**
- **Returned files can be split to accommodate onboard email file size limitations**
- **1500 systems connected to the Jeppesen service in November**
- **Over 6000 connections in total in January – and average of 4 per system.**
- **Average file size sent was 150kb**
- **97% success rate throughout the year**

# C-MAP Online+

- Downloads Notice to Mariners, New Editions and New Charts
- Requires Broadband connection (VSAT, Fleet etc.)
- Approximately 6.5Mb per week for Professional+
- Approximately 8.9Mb per week for our ENC database
- Can be transferred to a DVD or USB Pen and copied to other systems
- User friendly “Wizard” interface



# C-MAP Dynamic Licensing

## *'Pay as you go'*

- **A user friendly and cost effective method of Buying, Licensing, Using and Updating ENC charts onboard vessels**
- All ENCs are loaded and available onboard at all times
- Automatic licensing for the minimum period allowed
- ENC's that are not used are not re-licensed
- Replaced ENC's are automatically licensed
- Automatic reporting via the C-MAP Update Service
- Controlled costs via pre-set budgets and spending limits
- The license is always valid for a period of 3/6/9/12 months, from the first day it was needed
- No complicated logistics

# C-MAP Dynamic Licensing

## So how does it work?

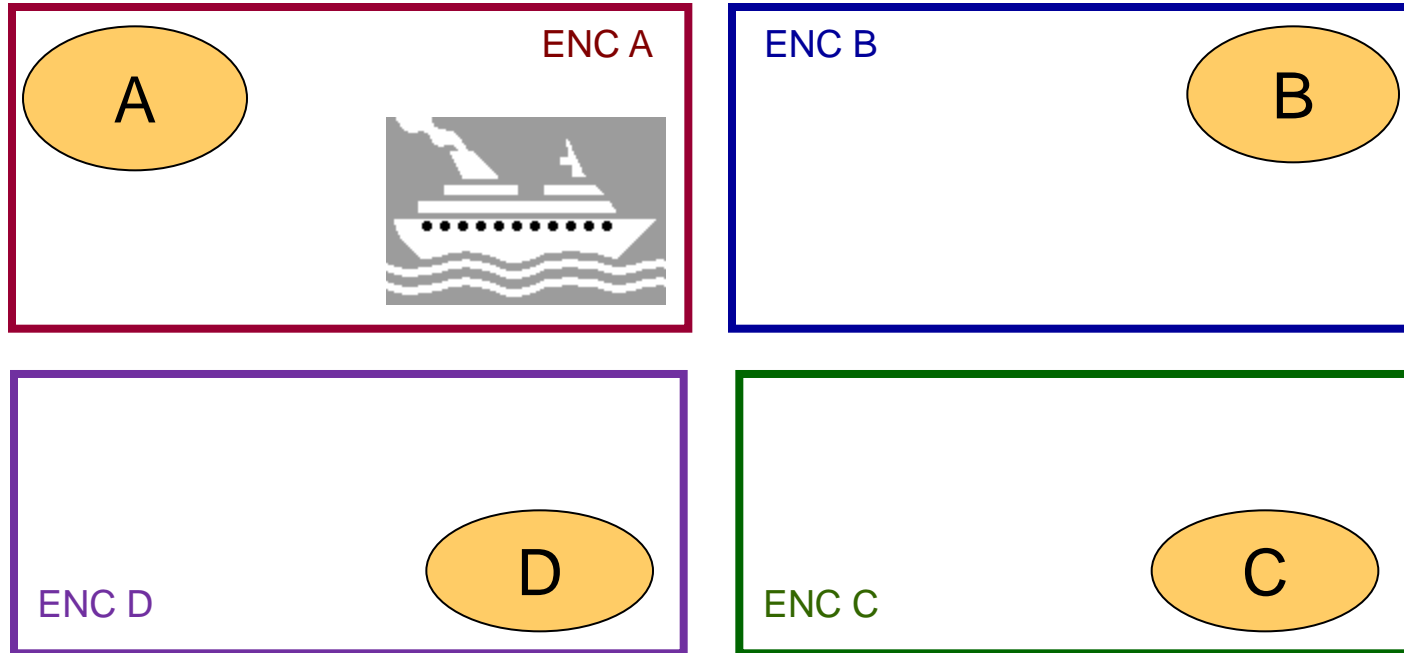

For three months our ship only operates in Area A

# C-MAP Dynamic Licensing

## So how does it work?

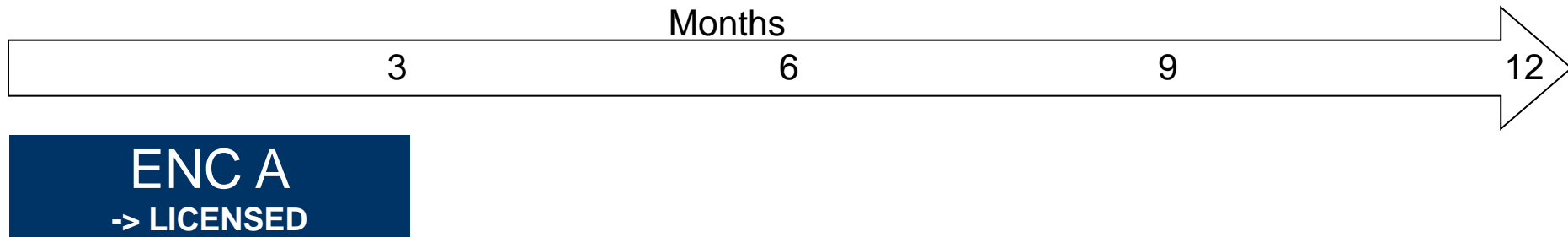

# C-MAP Dynamic Licensing

## So how does it work?

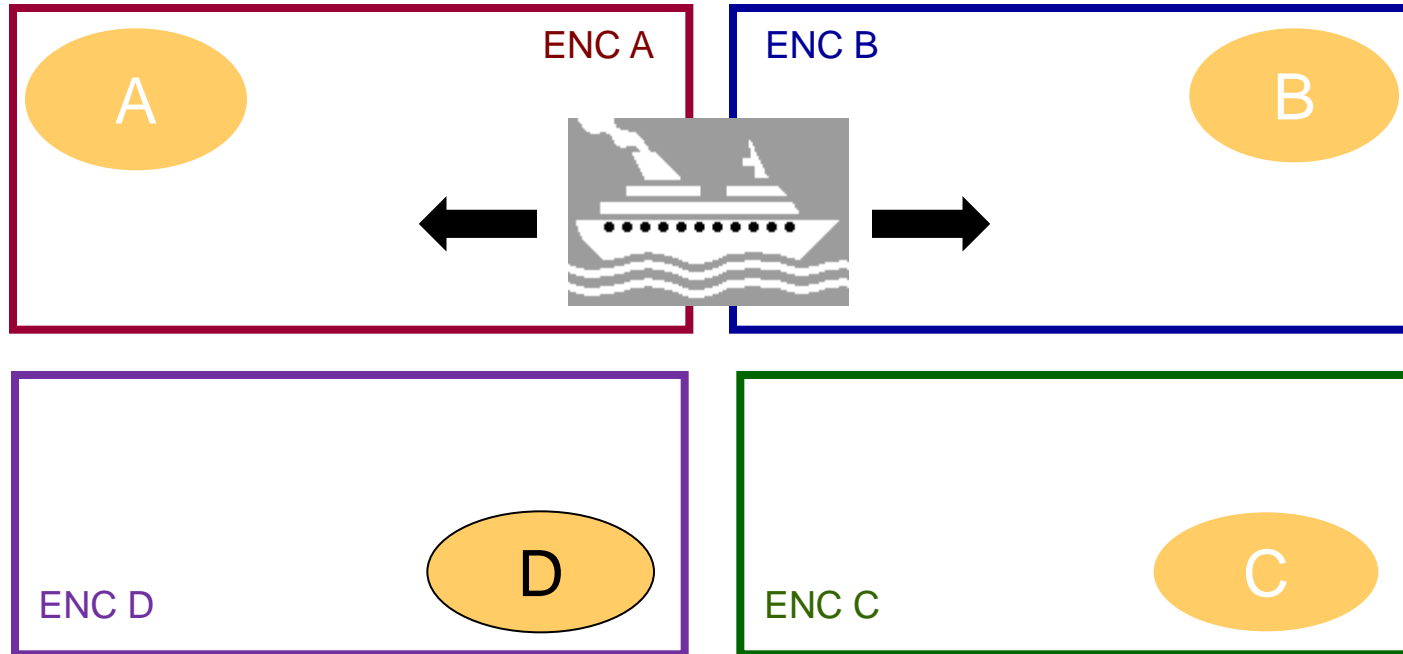

After 2 months our ship moves to operating between Area A and Area B and does so for another month

# C-MAP Dynamic Licensing

## So how does it work?

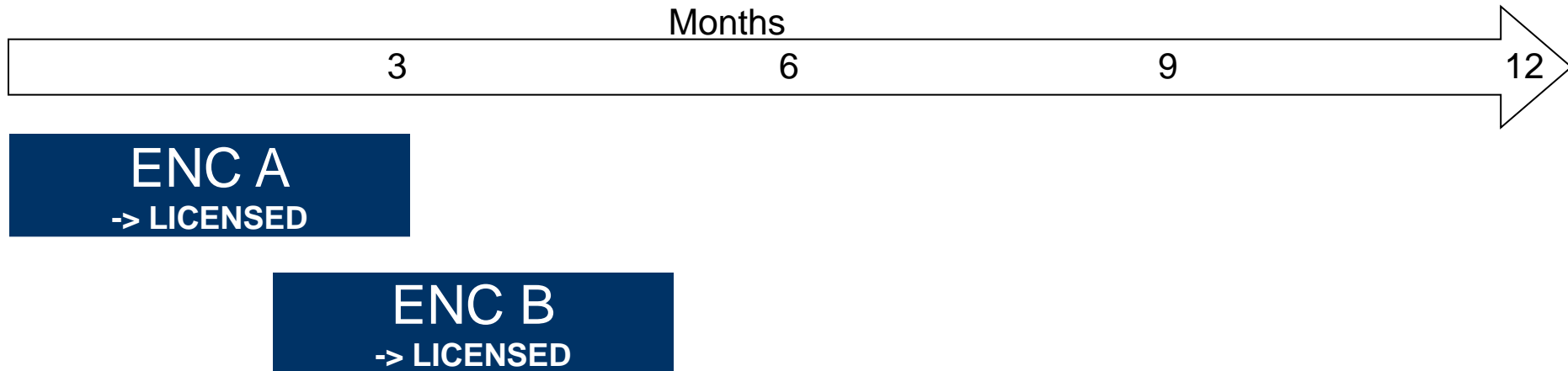

# C-MAP Dynamic Licensing

## So how does it work?

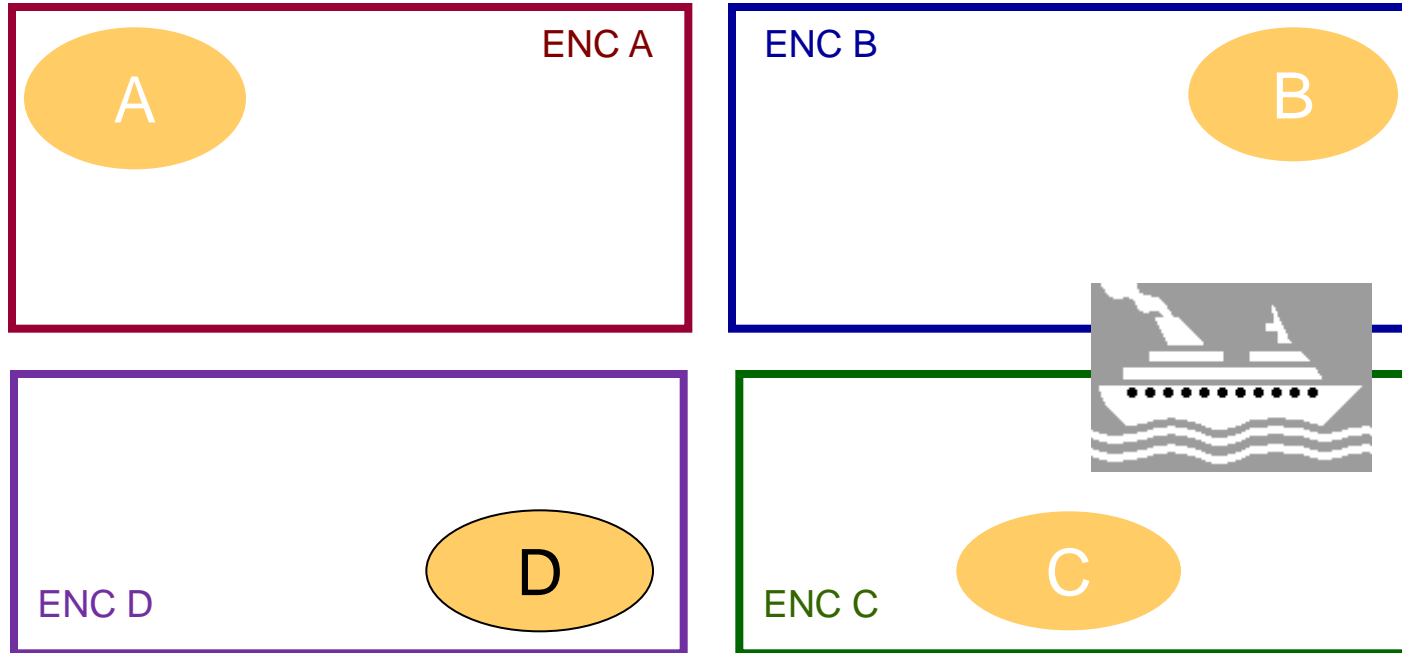

After 3 months our ship moves to operating between Area B and Area C and no longer visits Area A

# C-MAP Dynamic Licensing

## So how does it work?

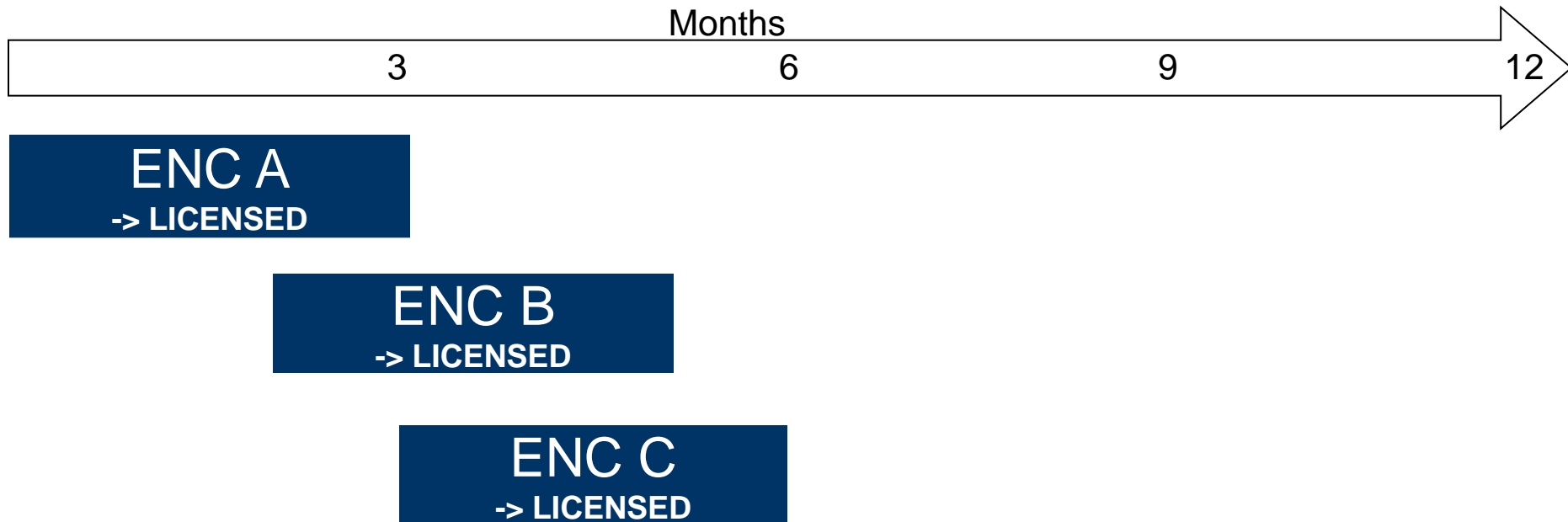

# C-MAP Dynamic Licensing

## So how does it work?

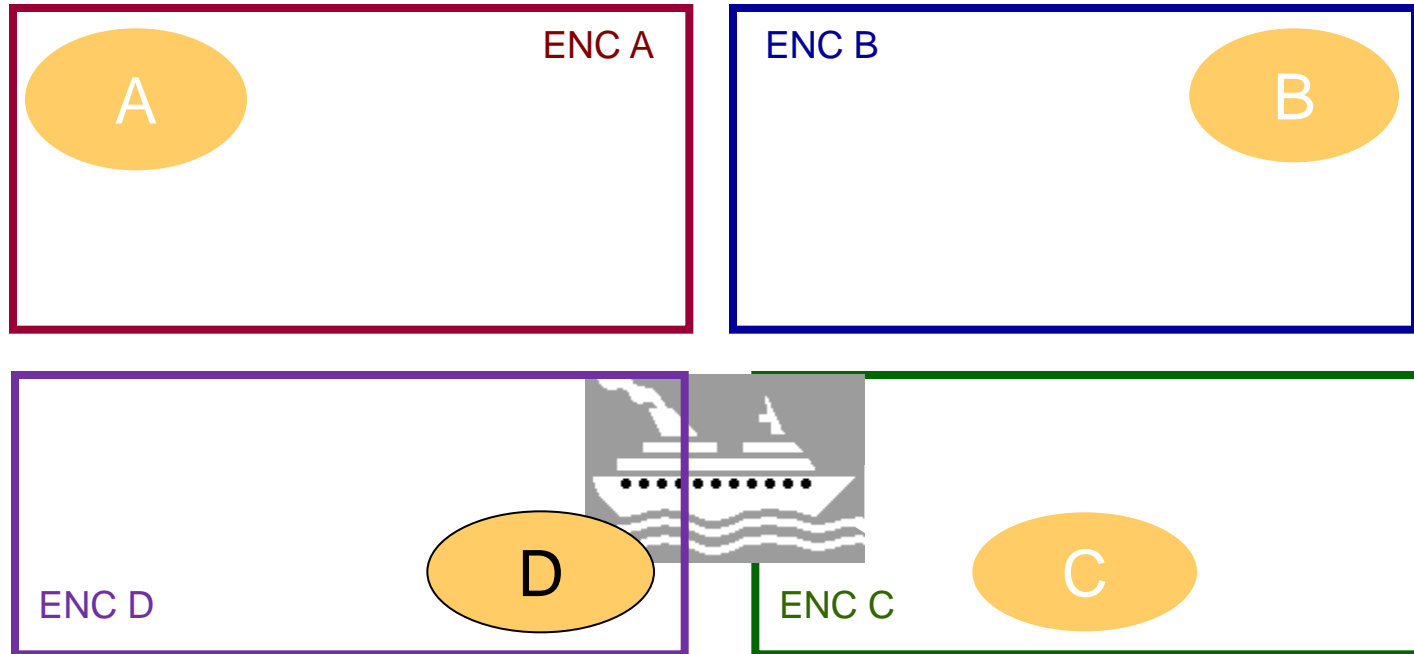

After 6 months our ship is assigned to operate for the remainder of the year between Area C and Area D, and no longer visits Areas A or B

# C-MAP Dynamic Licensing

## So how does it work?

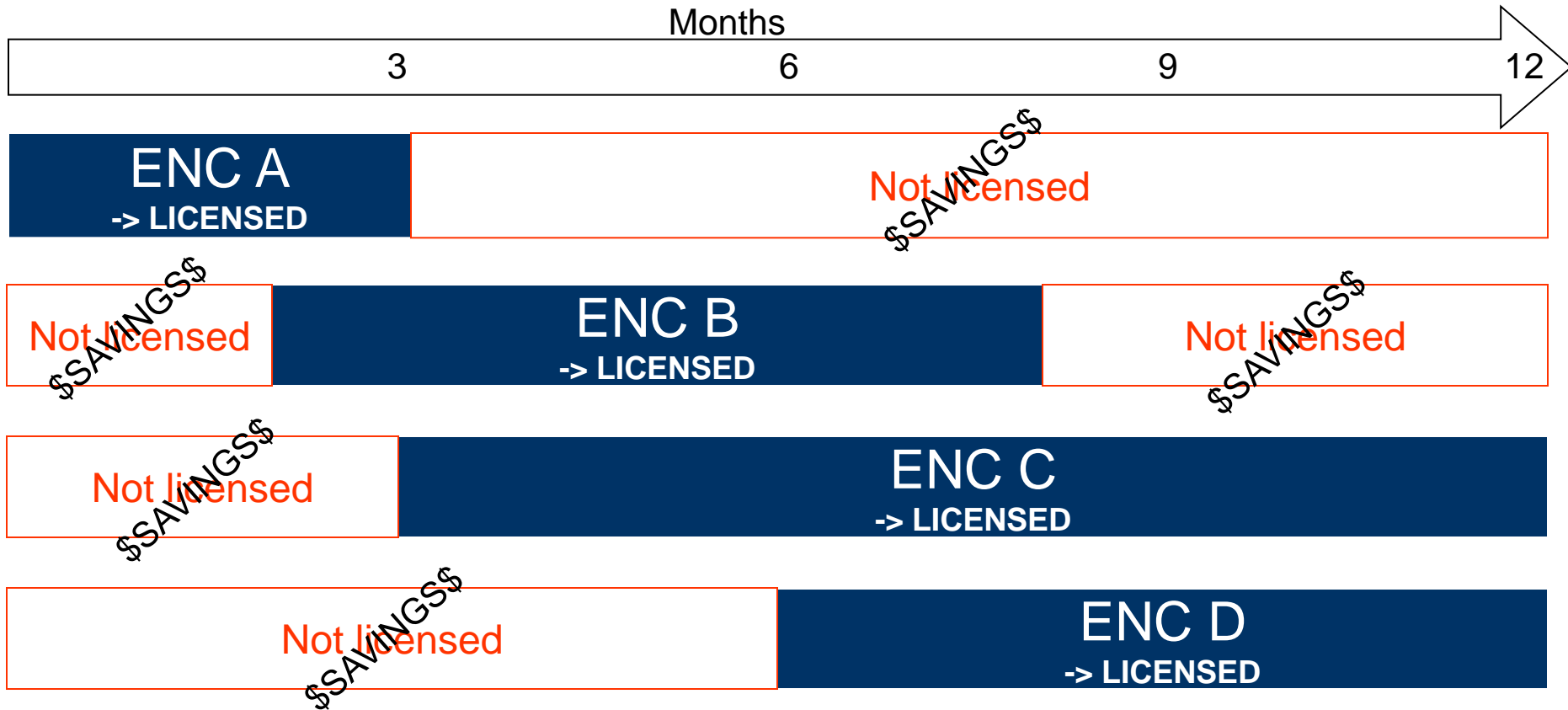

# And the savings are...?

- ENC A licensed for just 3 months (33%)
- ENC B licensed for 6 months only (66%)
- ENC C licensed for 9 months (99%)
- ENC D licensed for 6 months (66%)

If the vessel purchased the 4 ENC charts at \$10 per chart the cost would be \$40

With C-MAP Dynamic Licensing the cost would be approximately \$27. Multiply these figures with a realistic portfolio and the savings are as much as **40% to 50%**

**C-MAP Dynamic Licensing makes this logistically possible because everything is handled automatically**

# Who Can Use the Service?

## 35 ECDIS Systems use C-MAP technology

Manufacturer	Product	Update Service	C-MAP ENC	Dual Fuel	ECDIS Approval	Weather Service	Oceanview Route Exchange	Dynamic Licensing
Telko AS	TECDIS	✓	✓	✓	✓	✓	✓	Planned 2008
Sperry Marine	VMS VT	✓	✓	✓	✓	Planned 2008	✓	Planned 2009
L-3 Navigation	NaviNet ECDIS	✓	✓	✓	✓	✓	✗	Planned 2008
Sperry Marine	NaviECDIS	✓	✓	✓	✓	Planned 2008	✓	✗
Sperry Marine	Vision 2100	✓	✓	✓	✓	Planned 2008	✓	✗
Totem Plus	Totem ECDIS	✓	✓	✓	✓	Planned 2008	✗	✓
Furuno	FEA 2107/2807	✓	✓	✓	✓	✗	✓	✗
Tokyo Keiki	ECDIS EC-8000	✓	✓	✓	✓	✗	✗	✓
Tokyo Keiki	ECDIS EC-8500	✓	✓	✓	✓	✗	✗	✓
Kongsberg Maritime	K-Bridge ECDIS	✓	✓	✓	✓	✗	✗	✗
PC-Maritime	Navmaster ECDIS	✓	✓	✓	✓	✗	✗	✗
Sea Information Systems	Sea Information Systems	✓	✓	✓	✓	✗	✗	Planned 2008
Tokyo Keiki	ECDIS EC-7500	✓	✓	✓	✓	✗	✗	Planned 2009
Converteam	Marine Series HMI	✓	✓	✓	✓	✗	✗	✗
Dalian LandSea		✓	✓	✓	✓	✗	✗	✗
DMU China	EAR	✓	✓	✓	✓	✗	✗	✗
GEM	ECD-600 / ECD-700	✓	✓	✓	✓	✗	✗	✗
ICAN	NA	✓	✓	✓	✗	✗	✗	✓
JRC	JAN-701	✓	✓	✓	✓	✗	✗	✗
JRC	JAN-901M	✓	✓	✓	✓	✗	✗	✗
Navico	CS58	✓	✓	✓	✓	✗	✗	✗

Full list to be found at [www.c-map.no](http://www.c-map.no)

# Product and Services

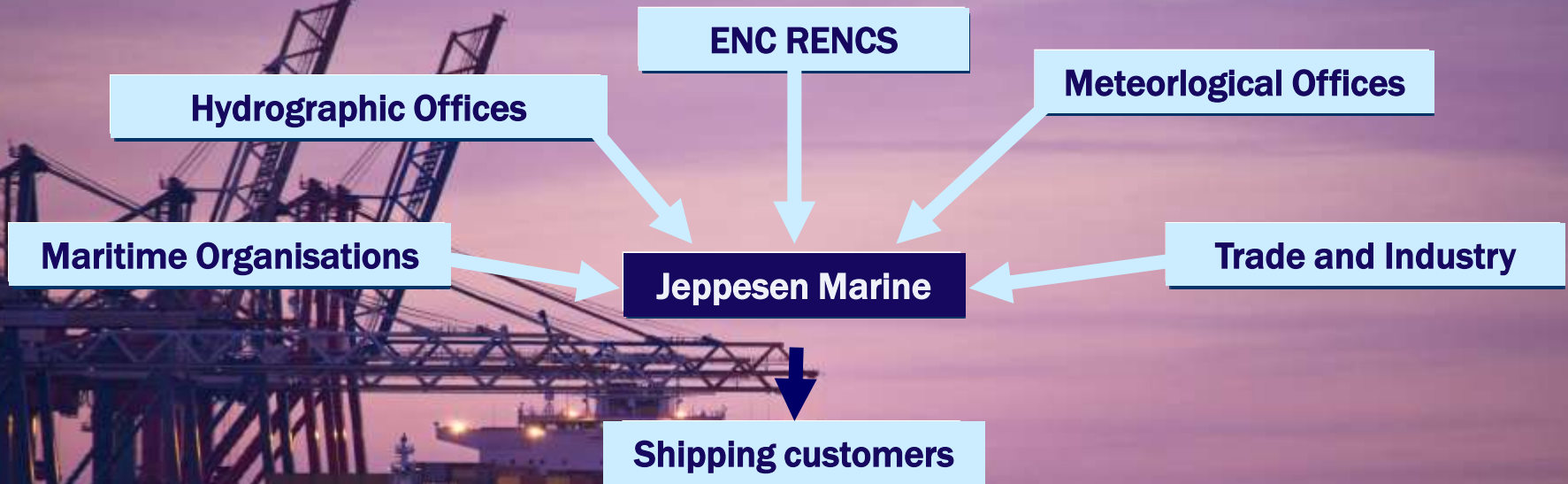

# Jeppesen Piracy Service

- Global Piracy Data
- Updated Daily
- Can be combined with
  - ECDIS route planning
  - Weather
  - No Go Zones

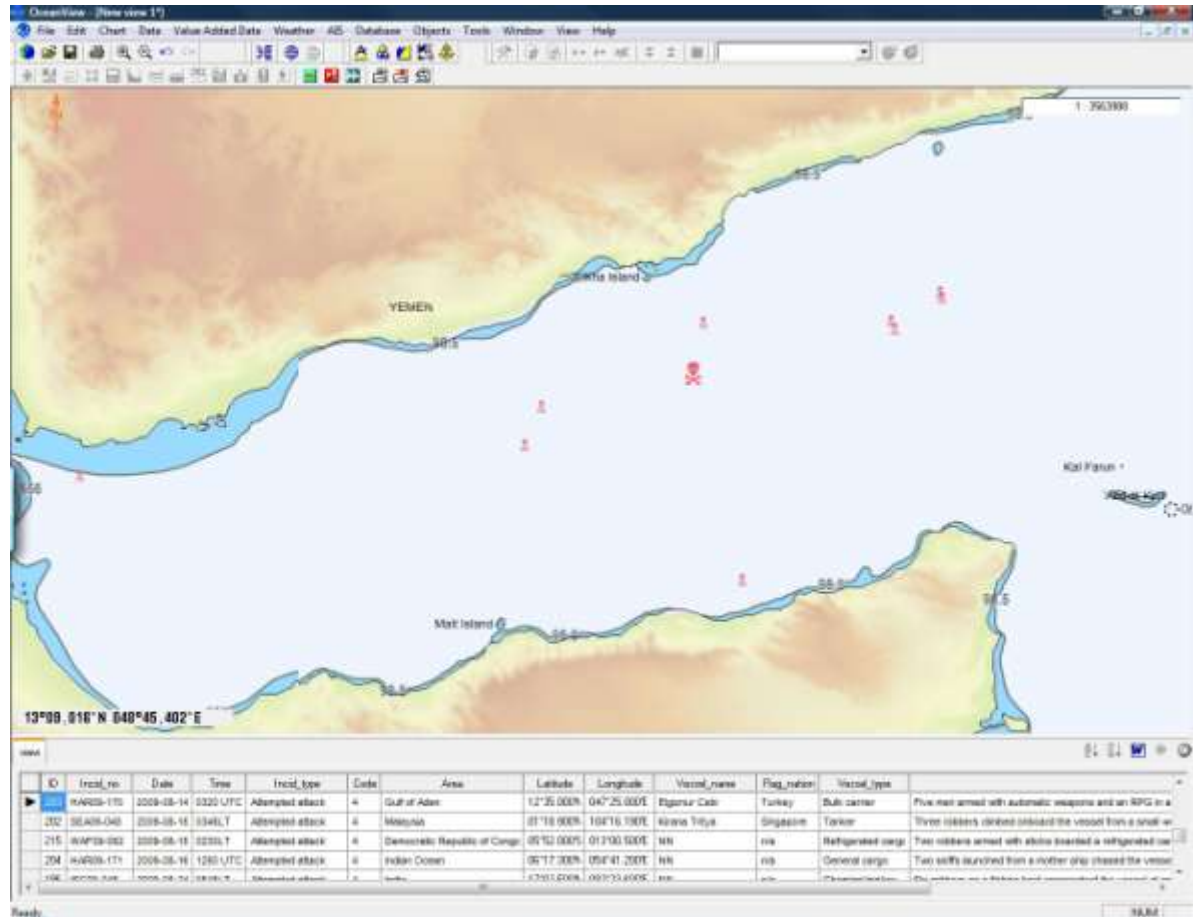

**BERGENRISK SOLUTIONS**

**JEPPESEN**  
MARINE



**THANK YOU!**

**[www.jeppesen.com](http://www.jeppesen.com)  
[eric.james@jeppesen.com](mailto:eric.james@jeppesen.com)**